



Automation+Robotik
ZUBEHÖR



Wechsel-Greiffinger-Rohling

zu Greifergröße 1

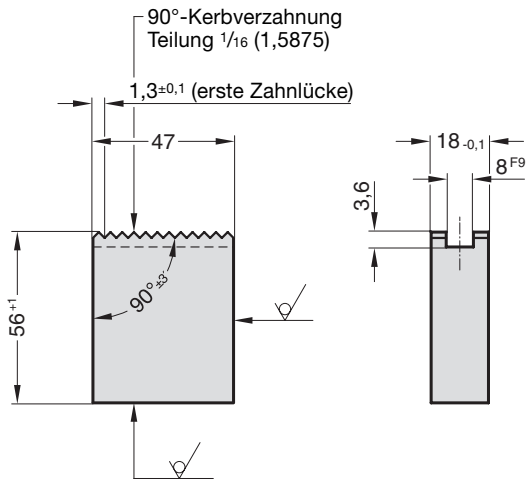

Werkstoff:

16 MnCr5
Gewicht 0,36 kg

Bestell-Nummer:

Wechsel-Greiffinger-Rohling = 0.510.01112

zu Greifergröße 2

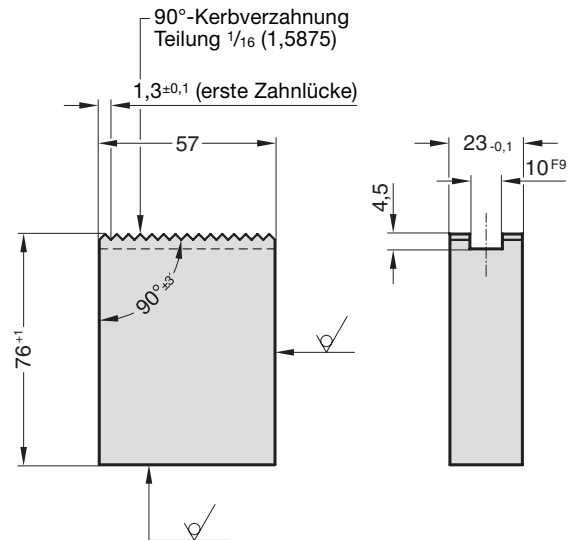

Werkstoff:

16 MnCr5
Gewicht 0,75 kg

Bestell-Nummer:

Wechsel-Greiffinger-Rohling = 0.510.01113

zu Greifergröße 3

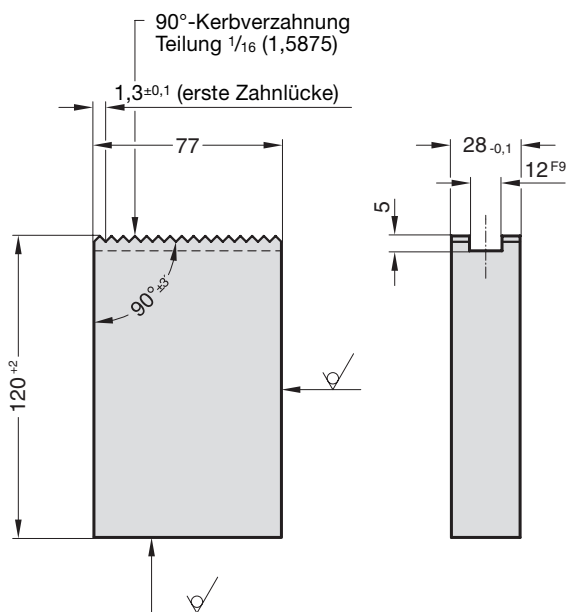

Werkstoff:

16 MnCr5
Gewicht 2,0 kg

Bestell-Nummer:

Wechsel-Greiffinger-Rohling = 0.510.01056

zu Greifergröße 4

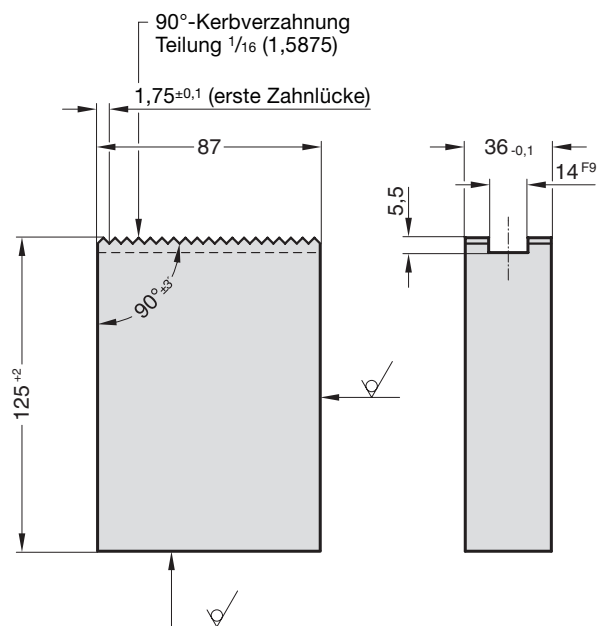

Werkstoff:

16 MnCr5
Gewicht 3,10 kg

Bestell-Nummer:

Wechsel-Greiffinger-Rohling = 0.510.01114



Zentrierring

zu Greifergröße 1

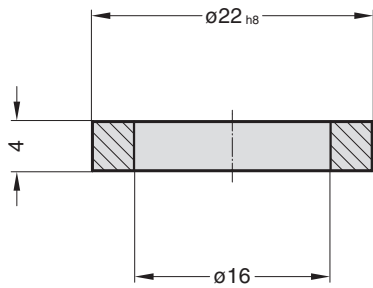

Gewicht 6 g

Bestell-Nummer:

Zentrierring = 0.181.01135

zu Greifergröße 2

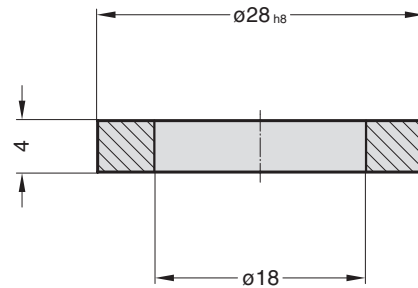

Gewicht 12 g

Bestell-Nummer:

Zentrierring = 0.181.00795

zu Greifergröße 3

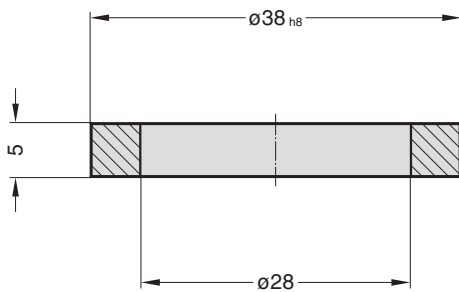

Gewicht 20 g

Bestell-Nummer:

Zentrierring = 0.181.00796

zu Greifergröße 4

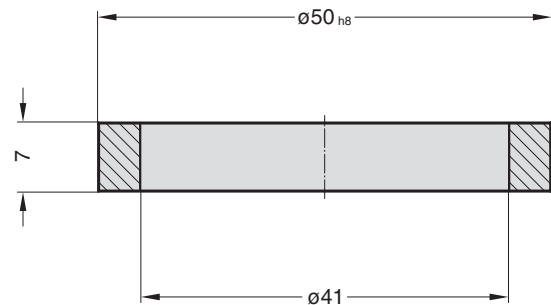

Gewicht 35 g

Bestell-Nummer:

Zentrierring = 0.181.00801

Empty rectangular box for text or drawing.



Large empty rounded rectangular box for drawing or detailed notes.